

Operating instructions for jaw crusher type BB300

Retsch[®]

Notes on the operating instructions

These operating instructions for the jaw crusher type BB 300 provide all the necessary information on the topics listed in the table of contents.

The guide the target group(s) defined for the relevant subjects in safe and proper handling of the BB 300. Knowledge of the relevant chapters by the appropriate target group(s) is essential for safe and proper handling.

This technical documentation comprises a reference work and a training guide. The individual chapters are self-contained units.

These operating instructions do not contain any instructions on repairs. Should any repairs become necessary, please contact your supplier or Retsch GmbH.

Notes on the operating instructions	2
Safety	4
Notes on safety.....	4
Warning symbols.....	5
Repairs	5
Confirmation	5
Technical data	6
Use for the intended purpose	6
Gap adjustment.....	6
Throughput, final fineness.....	6
Degree of protection	6
Rated power.....	6
Noise data	6
Equipment dimensions	7
Mounting surface required.....	7
Dimensional chart	8
Transport and installation	9
Packaging.....	9
Transport.....	9
Interim storage	9
Parameters for the installation location	10
Installation.....	10
Hopper assembly.....	10
Electrical Connection	11
Operation	12
Graphical representation of the controls.....	12
Overview table for the graphic	13
Starting the BB 300.....	14
Stopping the BB 300	14
Setting the gap width.....	14
Adjusting the zero position of the gap width indicator.....	14
Feeding in process material	15
Notes on working procedures	16
General	16
Input grain size.....	16
Quality of process material	16
Capacity	16
General	17
Cleaning.....	17
Maintenance.....	17
Tests	17
Replacing crusher jaws	18
Accessories.....	18
Copyright.....	18
Modifications	18
Safety instructions (table).....	19
Appendix	following pages

Safety

Target group: All persons dealing with the machine in any way

The BB 300 is a modern, powerful product from Retsch GmbH. It reflects the state of the art. When the machine is handled correctly by persons familiar with this technical documentation, it is completely safe and reliable in operation.

Notes on safety

You, as the operator, are responsible for ensuring that the persons appointed to work with the BB 300:

- have read and understood all the stipulations of the chapter on safety,
- are familiar before commencing work with all instructions and regulations for the relevant target group,
- have access to the technical documentation for this machine at all times and without difficulty.

Ensure that new staff have been familiarised with the rules for safe and proper handling before commencing work on BB 300 either by oral instruction by a competent person and/or by this documentation.

Incorrect operation can lead to damage or injury. You are responsible for your own safety and that of your staff.

Ensure that no unauthorised persons have access to the BB 300.

For your own protection, have your staff confirm that they have been instructed in operation of the BB 300. A draft of an appropriate form can be found at the end of the chapter on safety.

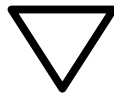

No liability in any form will be accepted for damage or injury resulting from failure to observe the following notes on safety.

Warning symbols

We use the following symbols to warn of:



Personal injury

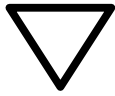

Damage to property

Repairs

These operating instructions do not contain any instructions on repairs. For your own safety, only have repairs performed by Retsch GmbH or an authorised agent (service technicians).

In such a case, please inform:

The Retsch agency in your country
Your supplier
Retsch GmbH direct

Your service address:

Confirmation

I have read and understood the foreword and the chapter on safety.

Signature of the operator

Signature of service technician

Technical data

Target group: Owners, operators

Machine type designation: BB 300

Use for the intended purpose

This machine is not designed as a production machine or for continuous operation, but as a laboratory machine intended for 8 hour single shift operation.

The BB 300 is suitable for crushing of medium to extremely hard substances and brittle and hard/tough materials. The achievable final fineness can be up to 5 mm and less, depending on the input material.

The maximum input grain size is <130 mm.

The materials which can be crushed in the BB 300 include the following:

concrete // ores // rock // glass // ceramics // coal // minerals // slags // cement clinker etc.

Should you require any further details, the Retsch applications laboratory will be pleased to assist.



Do not modify the machine in any way, and use only spare parts and accessories approved by Retsch.

The conformity with European Directives declared by Retsch will otherwise be invalidated.

Furthermore, this will lead to all warranty claims being rendered null and void.

Gap adjustment

From 1 mm to approx. 40 mm by means of a spindle.

Throughput, final fineness

The performance data, throughput and achievable final fineness are dependent on the breakage behaviour and hardness of the process material and on the gap width set. They can only be determined empirically.

Degree of protection

IP55

Rated power

3000 watts

Noise data

Noise measurement to DIN 45635-31-01-KL3

The noise levels are also decisively influenced by the properties of the material to be ground.

Example 1 :

Sound power level $L_{WA} = 95.7$ dB(A)

Workplace related emission level $L_{p,eq} = 81.5$ dB(A)

Service conditions :

Input material: Marble pebbles, grain size <90 mm

Gap width set: < 1 mm

Final grain size: < 14 mm

Filling of milling chamber: approx. 65%

Example 2:

Sound power level $L_{WA} = 102 \text{ dB(A)}$

Workplace related emission level $L_{p \text{ eq}} = 90 \text{ dB(A)}$

Service conditions:

Input material: Quartz pebbles, grain size $< 55 \text{ mm}$

Gap width set: $< 1 \text{ mm}$

Final grain size: $< 10 \text{ mm}$

Filling of milling chamber: approx. 65%

Equipment dimensions

Height: approx. 1450 mm

Width: approx. 670 mm

Depth: approx. 1600 mm

Weight: approx. 700 kg net

Mounting surface required

670 mm x 1600 mm; no safety clearances necessary!

Dimensional chart

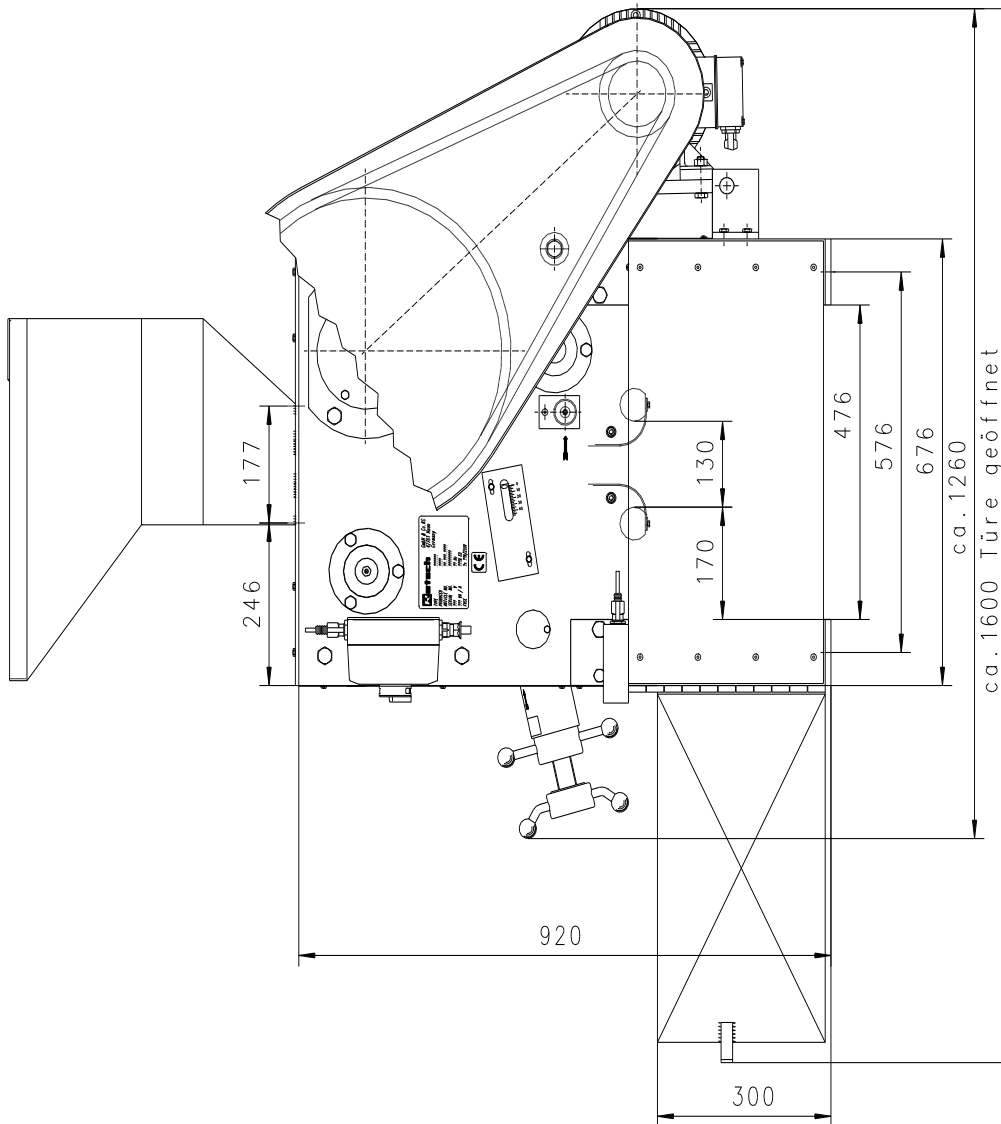
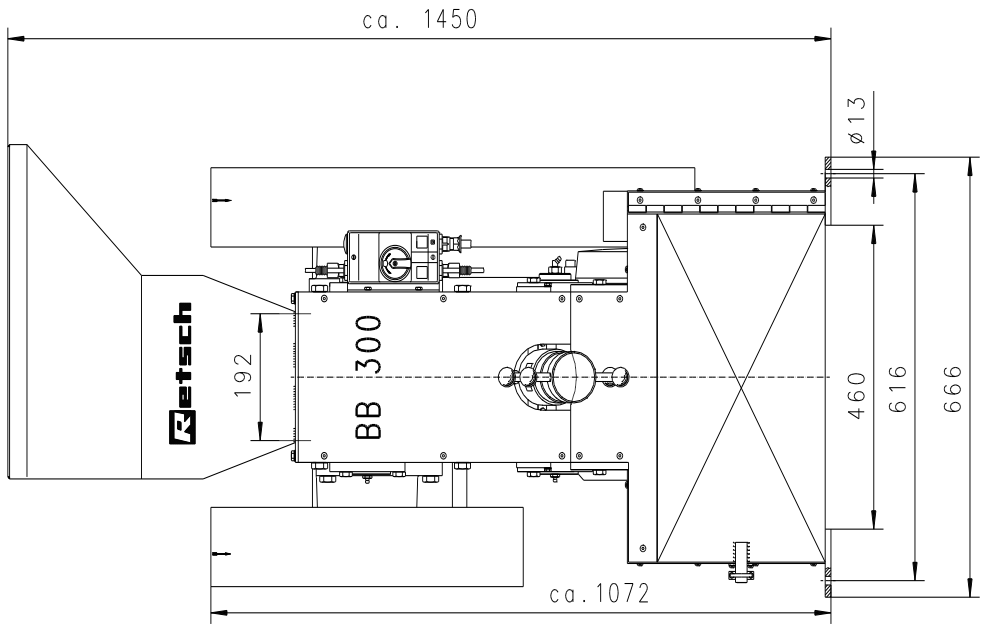

Transport and installation

Target group: Owners, carriers, operators

Packaging

The packaging is suitable for the mode of transport selected. It complies with the general packaging regulations.

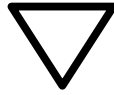

Please keep the packaging for the duration of the guarantee period, as your guarantee claim will be endangered in the case of a complaint or return of the machine in inadequate packaging.

Transport

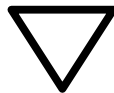

The BB 300 must not be thrown, subjected to impact or shock during transport. The electrical and mechanical components may otherwise be damaged.

The recommended temperature range for the use of the device (-25 °C to 55 °C ambient temperature) should not be exceeded or fall short of during transport or storage.

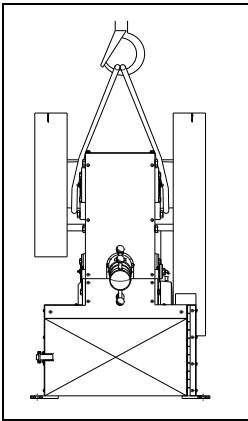

Fig.1

In order to handle the BB 300 by crane with a minimum load capacity of 1000kp, the feed hopper has been dismantled. The BB 300 can then be handled using appropriate lifting gear. One option is shown in **Fig. 1**.

Please loop the ropes around both bearing housings on the BB 300. **Fig. 1**

Interim storage

Also ensure that the BB 300 is stored in a dry location for interim periods.

Temperature fluctuations



When there are severe temperature fluctuations (e.g. during air transport) the BB 300 is to be protected from condensation. The electrical components may otherwise be damaged.

Parameters for the installation location

Ambient temperature:

5°C to 40°C

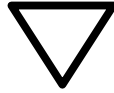

If the ambient temperature falls below or exceeds the limits specified, the electrical and mechanical components may be damaged or the performance data changed to an unknown extent.

Humidity:

Maximum relative humidity 80% at temperatures up to 31°C, decreasing in a straight line to 50% relative humidity at 40°C.

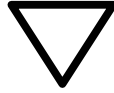

At higher humidity, the electrical and mechanical components may be damaged and performance data changed to an unknown extent.

Site altitude:

max. 2000 m above sea level

Installation

A mounting surface of 670mm in width and 1600mm in depth is required. The mouth of the feed hopper is at a height of approx. 1450 mm.

Install the BB 300 on an even, firm surface only. Anchoring is not absolutely necessary, as the free mass momentums induce only hardly perceptible vibrations in the vicinity. It can however be effected using the bores in the feet. **Fig.2**

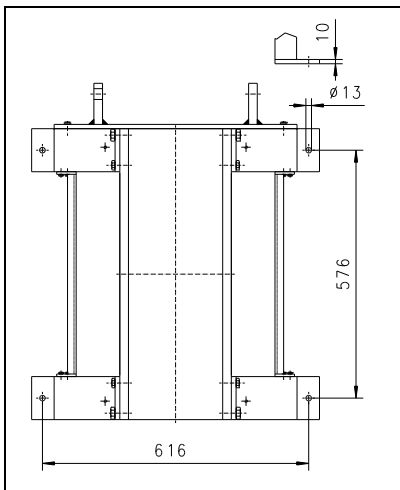

Fig.2

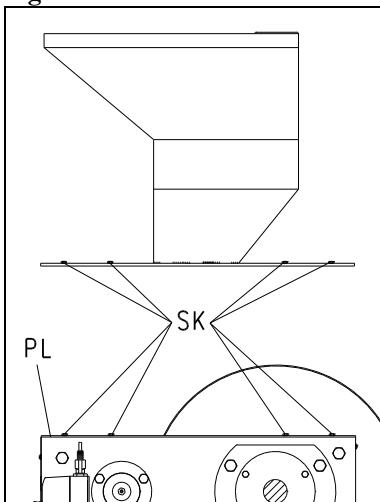

Fig.2a

Hopper assembly

In order to ensure safe transport, the BB 300 is delivered with the feed hopper dismantled.

A cover is fitted in place of the hopper to prevent inadvertent reaching into the machine. **Fig.2a**

- Remove the eight hexagon screws **SK** with a 13 mm AF spanner.
- Remove plate **PL**.
- Fit the feed hopper.
- Insert the eight hexagon screws **SK** and tighten them well with a 13 mm AF spanner.



Operation of the BB 300 without the feed hopper fitted is impermissible.

Risk of crushing fingers and hands!

Electrical Connection

The electrical connection must be established by a specialist electrician.

- Consult the type plate for the voltage and frequency of the BB 300.
- Ensure that the values are in agreement with the mains power supply.
- Connect the BB 300 to the mains using the cable supplied.

Ensure that there is an external fuse in accordance with the local regulations when connecting the unit to the mains supply.

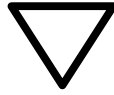

Failure to observe the values on the type plate can result in damage to electronic or mechanical components.

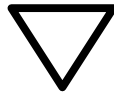

Prior to initial start-up, check the direction of rotation. See the direction arrow on the motor.

If the direction of rotation is incorrect, crushing performance is inadequate and mechanical components can be damaged.

Operation

Target group: Operators

Controls and operation

Graphical representation of the controls

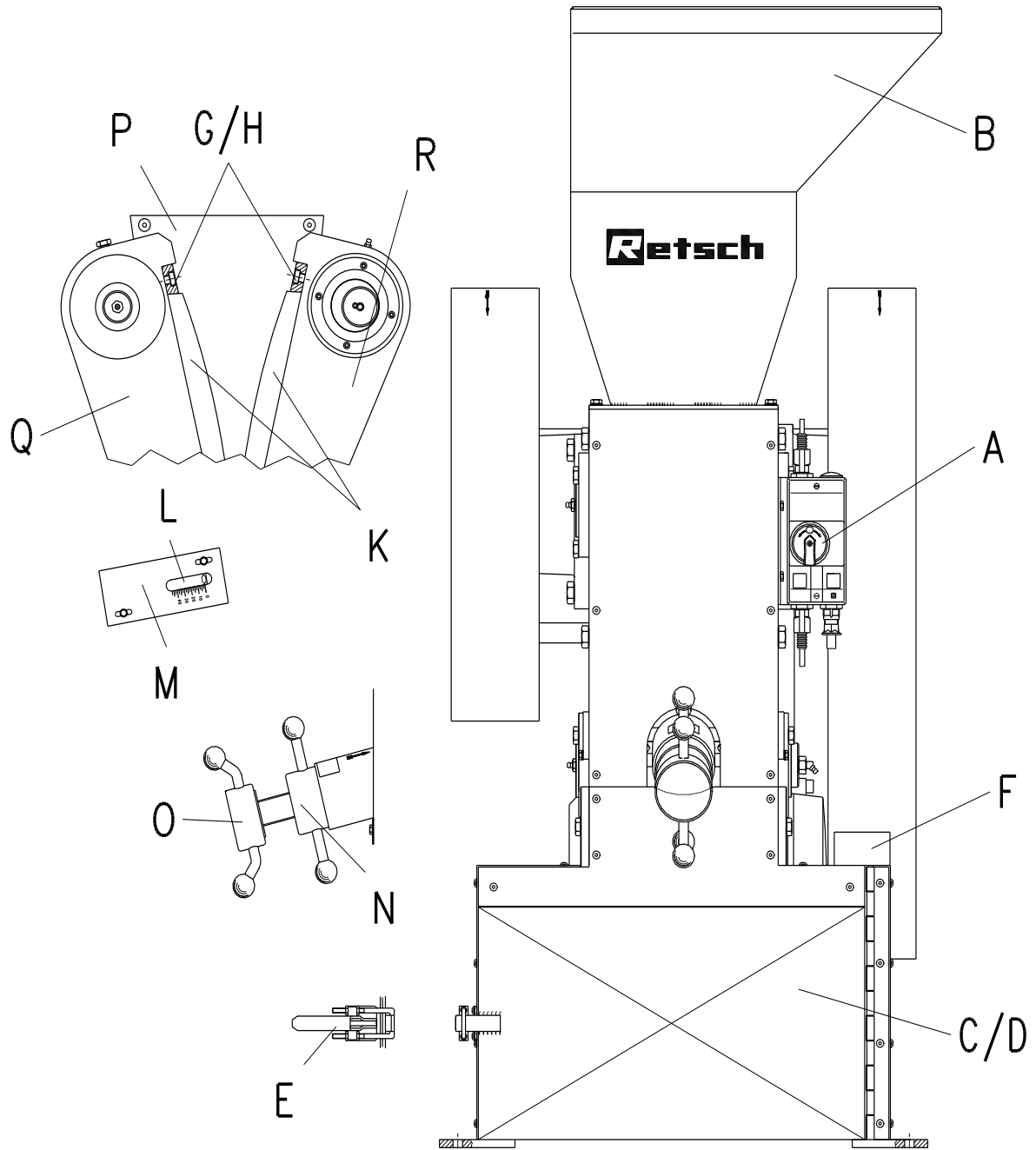
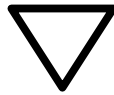

Fig.3

Overview table for the graphic

Control	Description	Function
A	ON/OFF and motor protection switch	Starts and stops the jaw crusher motor, interrupts the power supply when the motor is overloaded.
B	Feed hopper	Facilitates material feed, prevents inadvertent reaching into the crusher chamber, prevents ejection of process material.
C	Chamber for a collecting bin	A collecting bin with external dimensions: height = 280mm//width = 450mm//depth = 650mm can be inserted here. A collecting bin on rollers, V= 50l, is available as an accessory.
D	Door	Open = collecting bin can be inserted, BB 300 cannot be started. Closed = BB 300 can be started, inadvertent reaching into the machine is impossible.
E	Door catch	Prevents the door from opening of its own accord.
F	Limit switch	Stops the motor when the door is open.
G	Clamp	Fastens the crusher jaws K to the crusher arms Q and P.
H	Cheese head screw	Fastens clamp G
K	Crusher jaw	Pulverisation tool
L	Pointer	Indicates the gap width in conjunction with scale M, pitch 2.5 mm.
M	Scale	Indicates the gap width in conjunction with pointer L, adjusts the zero position of the gap width when the jaws are worn.
N	Lock nut	Locks the spindle O for gap width adjustment.
O	Spindle	Increases the gap width when turned anti-clockwise, reduces the gap width when turned clockwise.
P	Wear plates	Prevent wear on the side parts.
Q	Fixed crusher arm	Accommodates crusher jaw K, facilitates adjustment of gap width with spindle O.
R	Moving crusher arm	Accommodates crusher jaw K, performs the necessary crushing motion.

Starting the BB 300



The BB 300 may only be started with the crusher chamber empty. Process material fed into the crusher chamber or feed hopper before starting leads to blockages, and mechanical components may be damaged.

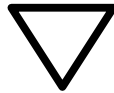

The same procedure also applies to restarting the BB 300!

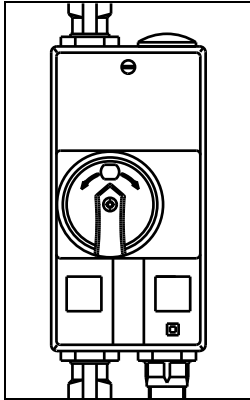

Fig.4

The ON/OFF switch is located on the front right of the BB 300.

Fig.4

- Turn the switch to the **ON** position.

The motor is started, and the moving crusher arm starts to move.

The crushing process can only be started when the door is closed and locked.

When the door is opened, a limit switch prevents the BB 300 from starting.

Stopping the BB 300

The ON/OFF and motor protection switch is located on the front right of the BB 300. **Fig.2**

- Turn the switch to the **OFF** position.

The motor is disconnected from the power supply and the moving crusher arm stops.

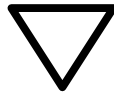

Only stop the BB 300 when there is no further process material in the crusher chamber.

Mechanical components can be damaged if there is blockage.

Setting the gap width

Fig.5

- Start the BB 300 (under no load).
- Release lock nut **N** (anti-clockwise).
- Turning spindle **O** clockwise reduces the gap.
- Turning spindle **O** anti-clockwise increases the gap.
- Pointer **L** roughly shows the gap on scale **M**, pitch 2.5 mm.
- Re-tighten lock nut **N** (clockwise)

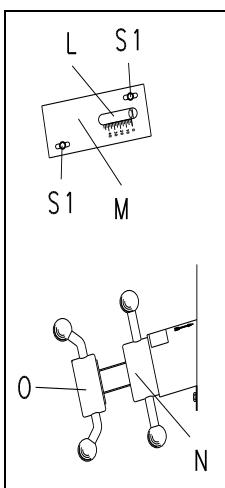
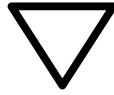

Fig.5

Adjusting the zero position of the gap width indicator

Fig.5

- Start the BB 300 (under no load).
- Release lock nut **N** (anti-clockwise).
- Carefully turn spindle **O** inwards (clockwise) until the two crusher arms just audibly meet.
- Release the hexagon or knurled head screws **S1** with an 8 mm AF spanner.
- Slide the “0” position on scale **M** to the zero position of pointer **L**.
- Re-tighten the hexagon or knurled head screws **S1**.



Do not set the gap width of the BB 300 to below 1 mm.
Mechanical components can be damaged if there is blockage.

Feeding in process material

The feed hopper **B** can accept process material with grain sizes up to 130 mm. Only fill the feed hopper and the crusher chamber when the machine is running.

The feed hopper is not however intended for storage of process material: its function is solely that of feeding material into the crusher chamber. It also prevents inadvertent reaching into the crusher chamber, and stops process material from being ejected.

Fig.6

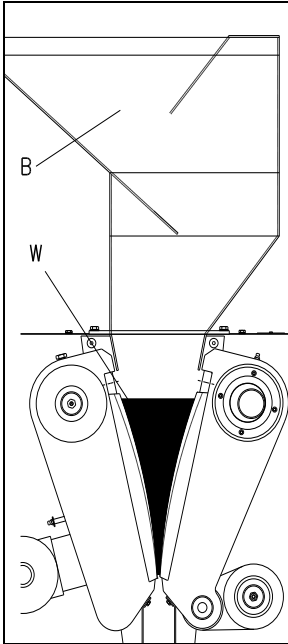
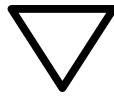

Fig.6



If the crusher chamber **W** is filled more than 2/3 (3500ml), the guide plates on the feed hopper can be damaged and process material conveyed by the moving crusher arm into the crusher casing behind the crusher arm.

Notes on working procedures

Target group: Laboratory technicians

General

The BB 300 is a robust free-standing machine which can predominantly be used for preliminary pulverisation of hard or brittle materials.

The performance data, throughput and achievable final fineness are dependent on the breakage behaviour and hardness of the process material, and on the gap width set.

Input grain size

The maximum input grain size is determined by the size of the intake opening, and is max. 130 mm on the BB 300.

Quality of process material

In principle, any hard and brittle process material with a Mohs hardness >3 can be crushed in the BB 300.

Moist or greasy process material with a Mohs hardness <3 tends merely to compact or cake in the crusher chamber as a result of the pressure applied by the crusher jaws.

Crushing is hardly possible in such cases.

Capacity

If the crusher chamber **W** is filled more than $2/3$ (3500ml), the guide plates on the feed hopper can be damaged and process material conveyed by the moving crusher arm into the crusher casing behind the crusher arm. **Fig.7**

The quantity of material in the machine also influences the proportion of fines in the pre-pulverised sample material. The more material in the crusher chamber, the higher the proportion of fines can be.

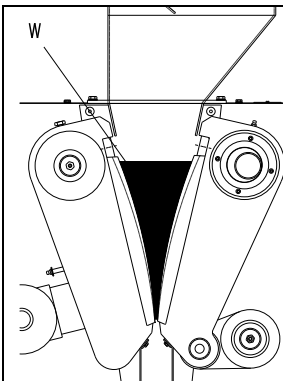

Fig.7



If the crusher chamber **W** is filled more than $2/3$ (3500ml), the guide plates on the feed hopper can be damaged and process material conveyed by the moving crusher arm into the crusher casing behind the crusher arm.

General

Cleaning

Cleaning of the BB 300 is best effected with an industrial vacuum cleaner and a robust, long-handled brush.



The feed hopper may only be dismantled by trained specialists, by removing the eight hexagon screws, for cleaning purposes. Operation of the BB 300 with the feed hopper removed is impermissible.

Risk of crushing fingers and hands!



Do not clean the BB 300 with running water.

Lethal hazard of electric shock

Solvents must not be used, as the felt seals on the sides of the crusher arms would be destroyed, and grease packing washed out.

Maintenance

The BB 300 requires relubrication from time to time. **Fig.8**

Please consult the table below for quantities of lubricant and intervals. The positions of the lubrication points are marked by red arrows on the machine.

No.	Quantity in kg	Interval in operating hours
1	0.025	50
2	0.005	50
3	0.003	500
4	0.005	500

Points not shown in **Fig.8** but marked with arrows are permanently lubricated.

Please use the grease gun supplied with the BB 300 for lubrication. As the lubricant, a conventional multipurpose grease can be used, e.g. EP 4685 from ESSO/SHELL or BP.

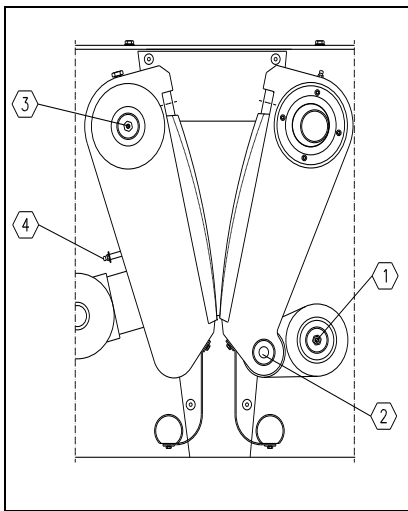

Fig.8

Tests

The function of the limit switch on the door is to be tested every six months. **Fig.9**

- Start the BB 300.
- Open catch **E**.
- Open door **D** until the gap on the left is 50 mm.
- Limit switch **E** must operate, and the BB 300 stop.

If the limit switch does not operate, it requires resetting as described below, or otherwise

- Close door **D** and catch **E**.
- The BB 300 must not start.
- Start the BB 300 at main switch **A**.

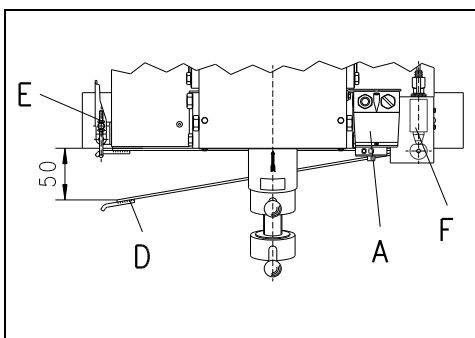

Fig.9

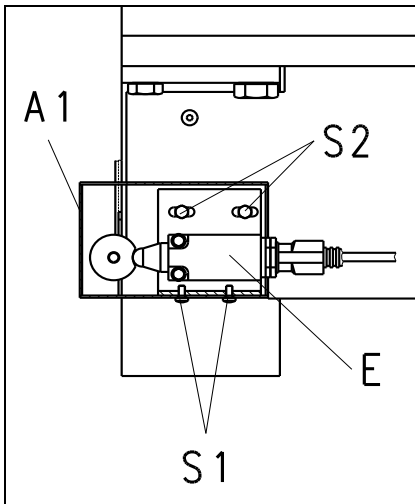

Fig.10

Notes on setting the limit switch

- Remove screws **S1**.
- Remove cover **A1**.
- Release screws **S2**, but do not remove them.
- Move the bracket with limit switch **E**.

The limit switch must operate as soon as the door is opened by max. 50 mm. **Fig.9**

- Re-tighten screws **S2**.
- Fit cover **A1** and fasten with screws **S1**.

Perform the test as described above under “Tests”

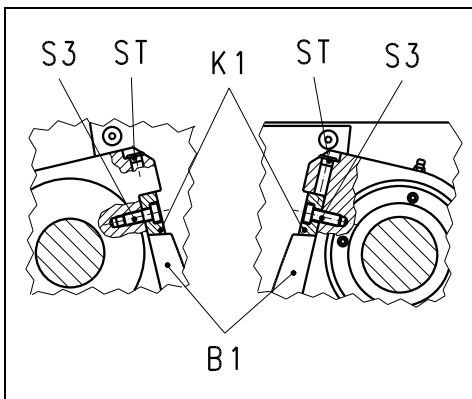

Fig.10

Replacing crusher jaws

- Disconnect the mains plug.
- Remove the feed hopper.
- Set the gap width to maximum.
- Remove cheese head screws **S3**.
- Remove clamps **K1**.
- Replace crusher jaws **B1**.

Should it prove difficult to remove the clamps, they can be prised off with a screwdriver. Proceed as follows:

- Remove plug **ST**.
- Insert the screwdriver through the bore which is now free.
- Tap lightly on the screwdriver with a plastic mallet.

After replacing the crusher jaws, always remember to re-tighten cheese head screws **S3** well and refit plugs **ST**.

- Fit the feed hopper and fasten it with the eight hexagon screws.

The feed hopper may only be dismantled by trained specialists, by removing the eight hexagon screws, for cleaning purposes. Operation of the BB 300 with the feed hopper removed is impermissible.

Risk of crushing fingers and hands!



Accessories

- Collecting bin on rollers, V=50 litres

Copyright

This documentation may only be duplicated or passed on to third parties, its contents passed on or otherwise used with the express approval of Retsch GmbH.

Violators will be liable for damages.

Modifications

We reserve the right to make technical modifications without notice.

Safety instructions (table)

for the BB 300 taken from the chapters

Procedure	Action	Dangers
Safety	Not paying attention to the safety instructions can lead to damage to people and property.	Claims for damage are excluded in whatever form.
Packaging	Please retain the packaging for the duration of the guarantee period.	In the case of complaint your warranty rights can be endangered if the item is returned insufficiently packaged
Transport	During transportation the BB 300 should not be knocked, shaken or thrown.	Electronic and mechanical components can become damaged.
Temperature variations	With severe variations in temperature, the BB 300 must be protected from condensation.	Electronic components can become damaged.
Scope of delivery	In the case of the delivery being incomplete and/or transport damage, you must inform the carrier and Retsch GmbH immediately (within 24 h).	Later complaints can under certain circumstances no longer be considered.
Environmental temperature	Drops below 5°C Rises above 40°C	Electronic and mechanical components can become damaged. Performance data change by an unknown extent.
Air humidity	Rises above 80% at temperatures up to 31%	Electronic and mechanical components can become damaged. Performance data change by an unknown extent.
Mounting the hopper	In order to be sure to be able to guarantee the transport, the BB 300 has been delivered with a dismounted filling hopper. It is not permissible to run the BB 300 without a filling hopper mounted.	Danger of crushing for fingers and hands.
Electrical connection	Mains supply does not match the values given on the type plate. Before initial operation, the direction of rotation is to be checked, see rotation direction arrow on the motor.	Electronic components can become damaged. If the direction of rotation is wrong, no satisfactory milling will take place and mechanical components can become damaged.
Operation	During starting, stopping and disconnection , there must be no material for grinding in the crushing chamber or in the feed hopper.	Mechanical components can possibly become damaged via a blockage.
	Do not set gap width below 1 mm.	Mechanical components can possibly become damaged via a blockage.
	The crushing chamber is not be filled by more than 2/3.	Otherwise the guide plates of the feed hopper can becoming damaged and the material for grinding will be delivered by the breaking arm into the crusher housing behind the arm.
Cleaning	Each time before cleaning, pull out the mains plug.	Danger of death by electrocution.
	Do not clean with running water.	Danger of death by electrocution.
	Solvents are not permitted.	Since they would damage the felt seals on the sides of the breaking arms or wash out the grease filling.
	The filling hopper may be swung back for cleaning, by unscrewing the two socket screws, only by assigned, trained personnel. Operation of the BB 300 without screwed-in socket screws and without the filling hopper is not permitted.	Danger of crushing for fingers and hands.

JAW CRUSHER

BB 300 | 20.054.1xxx

EU DECLARATION OF CONFORMITY

Herewith we declare, represented by the signatory, that the above mentioned device complies with the following directives and harmonized standards:

Machinery Directive 2006/42/EC

Applied standards, in particular:

DIN EN ISO 12100	Safety of machinery
DIN EN ISO 13857	Safety of machinery - Safety distances to prevent hazard zones being reached by upper and lower limbs
DIN EN 60204	Safety of machinery - Electrical equipment of machines
DIN 45635-31	Measurement of airborne noise emitted by machines; enveloping surface method, comminuting machines

EMC Directive 2014/30/EU

Applied standards, in particular:

DIN EN 61000-3-2	Electromagnetic compatibility (EMC)
DIN EN 61000-3-3	Electromagnetic compatibility (EMC)

Low Voltage Directive 2014/35/EU

Applied standards, in particular:

DIN EN 61010-1	Safety requirements for electrical equipment for measurement, control and laboratory use
----------------	--

Authorized person for the compilation of technical documents:

Stefan Drechsler (technical documentation)

Furthermore, we declare that the relevant technical documentation for the above mentioned device has been compiled according to Annex VII Part A of the Machinery Directive, and we undertake to submit this documentation on request to the market surveillance authorities.

In case of a modification of the device not previously agreed with Retsch GmbH, as well as the use of unauthorised spare parts or accessories, this declaration will lose its validity.

Retsch GmbH

Haan, 02/2021



Dr. Stefan Mähler, Team Leader R&D Department





Copyright

© Copyright by
Retsch GmbH
Haan, Retsch-Allee 1-5
D-42781 Haan
Federal Republic of Germany